

Requested Patent: EP0761194A2

Title: DISPOSABLE ABSORBENT UNDERGARMENT ;

Abstracted Patent: EP0761194 ;

Publication Date: 1997-03-12 ;

Inventor(s):

YAMAMOTO MASAMITSU (JP); FUJIOKA YOSHIHISA (JP); MUKAI HIROTOMO (JP);
ONO YOSHIO (JP); YAMAKI RUMI (JP); KITAZAWA WATARU (JP) ;

Applicant(s): UNI CHARM CORP (JP) ;

Application Number: EP19960306146 19960822 ;

Priority Number(s): JP19950217720 19950825; JP19950221976 19950830 ;

IPC Classification: A61F13/15 ;

Equivalent(s):

AU6219896, AU718109, CA2184039, DE69617566D, DE69617566T, US6364863 ;

ABSTRACT:

A disposable absorbent undergarment of pants type, such as a diaper (1), comprises short pants (2) and a liquid-absorbent pad (3) attached to an inner side of the short pants (2). The short pants (2) comprise a front waist section (6), a rear waist section (7) and a crotch section (8) interposed therebetween and have a waist-opening (9) and a pair of leg-openings (10). The short pants (2) are formed with first elastically stretchable regions defined by first elastic members (13) circumferentially extending in the proximity of the waist-opening (9) and second elastically stretchable regions defined by second elastic members (14) circumferentially extending parallel to the first elastically stretchable regions immediately above the crotch section which is longitudinally stretchable. Additionally, the crotch section (8) is provided with elastic means stretchable at least longitudinally of the crotch section (8).



(12) **EUROPEAN PATENT APPLICATION**

(43) Date of publication:
12.03.1997 Bulletin 1997/11

(51) Int Cl.⁶: **A61F 13/15**

(21) Application number: **96306146.0**

(22) Date of filing: **22.08.1996**

(84) Designated Contracting States:
BE DE FR GB IT NL SE

(30) Priority: **25.08.1995 JP 217720/95**
30.08.1995 JP 221976/95

(71) Applicant: **UNI-CHARM CORPORATION**
Kawanoe-shi Ehime-ken (JP)

(72) Inventors:

- **Yamamoto, Masamitsu**
Kawanoe-shi, Ehime-ken (JP)
- **Fujioka, Yoshihisa**
Mitoyo-gun, Kagawa-ken (JP)

- **Mukai, Hiroto**
Kawanoe-shi, Ehime-ken (JP)
- **Ono, Yoshio**
Kawanoe-shi, Ehime-ken (JP)
- **Yamaki, Rumi**
Kawanoe-shi, Ehime-ken (JP)
- **Kitazawa, Wataru**
Mitoyo-gun, Kagawa-ken (JP)

(74) Representative:
Murgatroyd, Susan Elizabeth et al
Baron & Warren
18 South End
Kensington
London W8 5BU (GB)

(54) **Disposable absorbent undergarment**

(57) A disposable absorbent undergarment of pants type, such as a diaper (1), comprises short pants (2) and a liquid-absorbent pad (3) attached to an inner side of the short pants (2). The short pants (2) comprise a front waist section (6), a rear waist section (7) and a crotch section (8) interposed therebetween and have a waist-opening (9) and a pair of leg-openings (10). The short pants (2) are formed with first elastically stretchable regions defined by first elastic members (13) circumferentially extending in the proximity of the waist-opening (9) and second elastically stretchable regions defined by second elastic members (14) circumferentially extending parallel to the first elastically stretchable regions immediately above the crotch section which is longitudinally stretchable. Additionally, the crotch section (8) is provided with elastic means stretchable at least longitudinally of the crotch section (8).

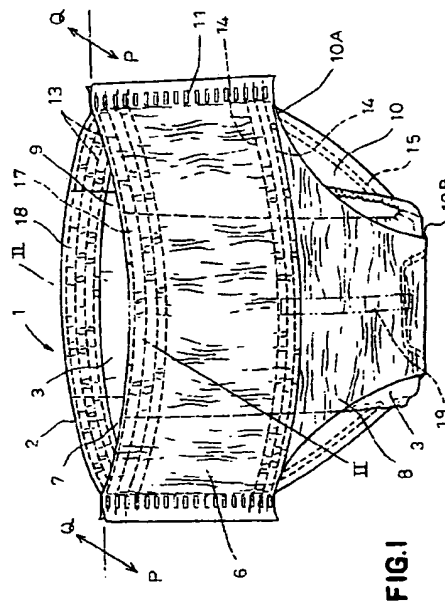

EP 0 761 194 A2

BEST AVAILABLE COPY

Description

The present invention relates to disposable absorbent undergarments and more particularly to undergarments such as pants type diapers, training pants for babies, pants for incontinent users or sanitary panties for disabled women.

It is known, for example, from Japanese Laid-Open Utility Model Application No. Hei6-21621 to bond longitudinally opposite ends of a liquid-absorbent auxiliary panel presenting a U-shaped curve to an inner side of a crotch section of disposable absorbent pants. This known pants intends to avoid an undesirable excretion leakage by fitting the auxiliary panel tightly against the wearer's crotch. Japanese Laid-Open Utility Model Application No. HeiS-62227 discloses a disposable diaper comprising an elongate elastic retaining member allowing a liquid-absorbent pad provided on a crotch section of the diaper to be fitted tightly against the wearer's crotch.

The above-mentioned prior art has the problem that short pants or diaper are inevitably subjected to a force tending to cause them to slip down when the liquid-absorbent auxiliary panel or the liquid-absorbent pad placed on the retaining member is tried to be fitted tightly against the wearer's crotch. Such slip-down of the short pants or diaper might be avoided by increasing a contracting force generated in an elastic member circumferentially extending around the wearer's waist, but such countermeasure will result in exerting an unacceptably high pressure upon the wearer's belly.

In view of the problem as described above, it is a principal object of the invention to provide an improvement in a disposable absorbent undergarment of pants type allowing a liquid-absorbent pad provided on a crotch section of short pants to be fitted tightly against the wearer's crotch without causing apprehension that the undergarment worn on the wearer's body might slip down.

The object set forth above is achieved, according to the invention, by a disposable absorbent undergarment comprising short pants and a liquid-absorbent pad, the short pants being defined by a front waist section, a rear waist section and a crotch section interposed between the two waist sections and having a pair of leg-openings and a circumferentially stretchable waist-opening, and the liquid-absorbent pad being attached to an inner side of the short pants so as to extend longitudinally from the crotch section into the front and rear waist sections, wherein:

the crotch section extending below upper ends of the leg-openings is provided with first elastic means which is stretchable at least longitudinally of the crotch section; a circumferential region defined by portions of the front and rear waist sections immediately above the crotch section is provided with second elastic means which is circumferentially stretchable; and the liquid-absorbent pad comprises a liquid-permeable topsheet, a

backsheet and a liquid-absorbent panel disposed between these two sheets with portions of the sheets extending outward beyond longitudinally opposite ends of the panel and being joined to the front and rear waist sections, respectively.

The invention will now be described by way of example with reference to the accompanying drawings, in which:-

Fig. 1 is a perspective view showing an embodiment of the invention in the form of a disposable diaper; Fig. 2 is a sectional view taken along a line II-II in Fig. 1;

Fig. 3 is a plan view showing the diaper as has been longitudinally opened;

Fig. 4 is a sectional view taken along a line IV-IV in Fig. 3;

Fig. 5 is a sectional view taken along a line V-V in Fig. 3;

Fig. 6 is a perspective view showing another embodiment of the invention in the form of disposable diaper;

Fig. 7 is a sectional view taken along a line II-II in Fig. 6;

Fig. 8 is a plan view showing the diaper as has been longitudinally opened;

Fig. 9 is a sectional view taken along a line IV-IV in Fig. 8; and

Fig. 10 is a sectional view taken along a line V-V in Fig. 8.

Figs. 1 and 2 exemplarily show a diaper 1 as a disposable absorbent undergarment of pants type according to the invention in a perspective view and a sectional view taken along a line II-II in this perspective view, respectively. The diaper 1 comprises short pants 2 and a liquid-absorbent pad 3 attached to an inner side of the short pants 2. The short pants 2 comprise, in turn, a front waist section 6, a rear waist section 7 and a crotch section 8. The short pants 2 further include a waist-opening 9 and a pair of leg-openings 10. The front and rear waist sections 6, 7 are bonded together intermittently in the vertical direction so as to define transversely opposite narrow strip-like regions 11, with their inner surfaces put one upon another along their respective transversely opposite side edges. Referring to Fig. 1, the front and rear waist sections 6, 7 are defined above upper ends 10A of the respective leg-openings 10 while the crotch section 8 is defined below the upper ends 10A. The front and rear waist sections 6, 7 have first elastically stretchable members 13 extending along a peripheral edge of the waist-opening 9 and second elastically stretchable members 14 extending circumferentially of the wearer's waist parallel to the first elastically stretchable members 13 and at a level immediately above the upper ends 10A of the leg-openings 10. The crotch section 8 includes, in addition to longitudinally stretchable plastic film 27 as will be described later in connection with Fig. 4, elasti-

cally stretchable members 15 extending substantially along halves of rear side peripheries of the respective leg-openings 10. The liquid-absorbent pad 3 longitudinally extends from the crotch section 8 into the front and rear waist sections 6, 7 and is joined at its longitudinally opposite ends 17, 18 to the front and rear waist sections 6, 7, respectively. The liquid-absorbent pad 3 is bonded inside of the short pants 2 also along an intermediate region 19 with respect to the longitudinally opposite ends 17, 18 and this region 19 for bonding is defined by a narrow strip-like region longitudinally extending along the transverse middle of the crotch section 8 so as to be positioned aside toward the front waist section 6. The bonding of the pad 3 is achieved by any suitable means, such as by hot melt adhesive.

Fig. 3 is a plan view showing the diaper 1 of Fig. 1 as has been separated along the narrow strip-like regions 11 and longitudinally opened in directions as indicated by arrows P, Q to show the inner sides of the front waist section 6 and the rear waist section 7. Referring to Fig. 3, the front and rear sections 6, 7 include first elastically stretchable regions W_1 extending around the waist-opening 9 and second elastically stretchable regions W_2 circumferentially extending parallel to the first elastically stretchable regions W_1 , both of which are 10 to 50mm wide and respectively defined circumferentially by the first and second elastically stretchable members 13, 14 each comprising a plurality of elastic elements so that the regions W_1 , W_2 present tensile stresses W_1 , W_2 in a relationship of $W_1 \geq W_2$. Third regions W_3 extending between the respective regions W_1 and W_2 may be circumferentially non-stretchable. The respective stresses W_1 , W_2 in the front waist section 6 may be adjusted to be different from the corresponding stresses in the rear waist section 7 and, in such a case, the respective stresses in the front waist section 6 will be preferably adjusted to be higher than the corresponding stresses in the rear waist section 7. The elastically stretchable member 15 extending substantially along halves of the rear side peripheries of the respective leg-openings 10 and describing curves on transversely opposite sides of the crotch section 8 is continuous between the right and left leg-openings 10. More specifically, they extend upward from points in the proximity of lower ends 10B of the respective leg-openings 10 (as will be apparent from Fig. 1) and then across an area of the crotch section 8 which is defined aside toward the front waist section 6. The crotch section 8 has a stretchability in its longitudinal direction owing to the presence of the stretchable plastic film 27 as will be described later in connection with Fig. 4 and, in addition, a stretchability along the peripheral edge of each leg-opening 10 which is enhanced by the elastically stretchable member 15.

The liquid-absorbent pad 3 is joined at its longitudinally opposite ends 17, 18 to the respective first stretchable regions W_1 extending together around the waist-opening 9. The region 19 of the crotch section 8 at which the pad 3 is bonded to the crotch section 8 has its lower

end 19B positioned aside toward the front with respect to the lower ends 10B of the leg-openings 10. The purpose of this region 19 is to avoid any apprehension that the pad 3 might be lifted off from the crotch section 8 and/or might be shifted transversely of the crotch section 8 during use of the diaper 1 and preferably has a width equal to a small fraction of the crotch section's width, for example, 1 to 3mm.

Referring to Fig. 4 which is a sectional view taken along a line IV-IV in Fig. 3, each of the front and rear waist sections 6, 7 of the short pants 2 comprises a laminate sheet consisting of a topsheet 21 made of hydrophilic or hydrophobic nonwoven fabric and a backsheet 22 made of hydrophobic nonwoven fabric intermittently bonded together, and the previously described first and second elastically stretchable members 13, 14 interposed between the topsheet 21 and the backsheet 22. The members 13, 14 are secured in a stretched condition to an inner surface of at least one of the topsheet 21 and the backsheet 22. The backsheet 22 is folded along the peripheral edge onto the inside of the short pants 2 and put upon the longitudinally opposite ends 17, 18 of the pad 3. The crotch section 8 comprises a crotch section topsheet 25 made of a hydrophilic or hydrophobic nonwoven fabric, a crotch section backsheet 26 made of a hydrophobic nonwoven fabric and a plastic film 27 which is stretchable at least in its longitudinal direction, liquid-impermeable and moisture-permeable. The film 27 is intermittently bonded in a stretched condition in its longitudinal direction to inner surfaces of the crotch section topsheet 25 and the crotch section backsheet 26. When the diaper 1 is not being worn by a user, the film 27 contracts to form a plurality of gathers in the crotch section 8 (as will be apparent from Fig. 1). Longitudinally opposite ends 30, 31 of the crotch section 8 are joined to the front and rear waist sections 6, 7, respectively, below the second stretchable regions W_2 circumferentially extending parallel to the waist-opening 9. The liquid-absorbent pad 3 is free from being bonded to the inner surface of the short pants between the longitudinally front end 17 and the region 19 as well as between the longitudinally rear end 18 and the region 19. While adhesive H (shown in Fig. 2) by means of which the short pants 2 and the pad 3 are bonded together can be seen also in Fig. 4, bonding means for the other components are not shown in Fig. 4.

Fig. 5 is a sectional view taken along a line V-V in Fig. 3, in which the elastically stretchable member 15 associated with the respective leg-openings presents their cross-sections in the proximity of transversely opposite side edges of the pants between the crotch section topsheet 25 and the film 27. The member 15 is secured in a stretched condition to the inner surface of at least one of the crotch section topsheet 25 and the film 27. The pad 3 comprises a panel 35 which includes, in turn, a shaped mixture of fluff pulp fibers and discrete particles of a water insoluble hydrogel covered with a tissue paper 37, a liquid-permeable topsheet 38 made

of a nonwoven fabric covering a top surface of the panel 35, a liquid-impermeable backsheet 39 made of a plastic film covering a bottom surface of the panel 35 and extending outward beyond transversely opposite side edges of the panel 35, and liquid-impermeable side sheets 42. The side sheets 42 are made of a nonwoven fabric and joined to an upper surface of lateral extensions of the backsheet 39 with their inner side edges 40 bonded to an upper surface of the topsheet 38 and their outer side edges 41 extending outward beyond transversely opposite side edges of the backsheet 39. The backsheet 39 may be liquid-permeable so far as the liquid-impermeable film 27 exists and/or the panel 35 has a sufficiently high liquid retaining ability. Each of the side sheets 42 contains an elastically stretchable member 45 in a stretched condition in the longitudinal direction of the pad 3 within a sleeve 43 formed by folding back an outer side edge of this side sheet 42 and longitudinally opposite ends of the member 45 are secured to the longitudinally opposite ends 17, 18 of the pad 3. The backsheet 39 is fixedly bonded at the region 19 to the upper surface of the crotch section topsheet 25 by means of hot melt adhesive H. With the diaper 1 assembled as shown in Fig. 1, the elastically stretchable members 45 contract between their longitudinally opposite ends and the backsheet 39 is curved integrally with the side sheets 42 as indicated by imaginary lines so as to fit closely around the wearer's legs and thereby to avoid sideway leakage of excretion.

When this diaper 1 is worn, the pad 3 can be reliably fitted against the wearer's crotch by longitudinally stretching the crotch section 8. A contracting force thereupon generated in the crotch section 8 in its longitudinal direction would otherwise cause the short pants 2 to slip down, but such possibility can be effectively reduced by the second elastically stretchable regions W_2 circumferentially extending around the wearer's waist parallel to the first elastically stretchable regions W_1 . The regions W_2 additionally prevent said contracting force generated in the crotch section 8 from affecting the first elastically stretchable regions W_1 circumferentially extending around the waist-opening 9. Consequently, no slip-down of the short pants 2 occurs even if the diaper 1 is worn with the pad 3 being tightly fitted against the wearer's crotch. In addition, the second elastically stretchable regions W_2 cooperate with the stretchable plastic film 27 to press the longitudinally opposite ends of the liquid-absorbent panel 35 against the wearer's body and at the same time to assure a desired fitting around the wearer's legs. The second elastically stretchable regions W_2 are different from the first elastically stretchable regions W_1 circumferentially extending in the proximity of the waist-opening 9 in that they can achieve the previously described slip-down preventing function without exerting an excessive pressure on the central zone of the wearer's belly even if their tensile stress is relatively high. Owing to the presence of the second stretchable regions W_2 having such func-

tion, no slip-down of the short pants 2 readily occurs if the tensile stress of the first stretchable regions W_1 is selected so as to be lower than that usually selected by the known short pants. The pad 3 is bonded to the inner side of the short pants 2 merely at its longitudinally opposite ends 17, 18 associated with the first elastically stretchable regions W_1 and at the relatively narrow region 19 defined in the crotch section 8 by a narrow strip-like area longitudinally extending along the transversely middle region of the crotch section 8 over an intermediate length between the longitudinally opposite ends 17, 18 of the pad 3 so as to be positioned aside toward the front waist section 6. Such arrangement is advantageous in that the presence of the pad 3 does not deteriorate the expected stretchability of the crotch section 8.

Another embodiment of the present invention is illustrated by a disposable absorbent undergarment 1A in Figs. 6 - 10, which have substantially the same structure and components as those previously described in connection with Figs. 1 - 5, and where the similar components have the same reference numeral as those of Figs. 1 - 5. It should be noted, therefore, that a description of the similar structure and components is omitted. This embodiment includes third elastically stretchable regions W_3 which are defined circumferentially by third elastically stretchable members 16 each comprising a plurality of elastic elements extending parallel to and between the first and second elastically stretchable members 13, 14, to provide a relatively low stretchability. A tensile stress of each region W_3 may be selected to establish a relationship of $W_3 < W_2$. The respective stresses W_1 , W_2 , W_3 in the front waist section 6 may be adjusted to be different from the corresponding stress in the rear waist section and, in such a case, the respective stresses in the front waist section 6 will be preferably adjusted to be higher than the corresponding stresses in the rear waist section 7.

Without departing from the spirit and the scope of the invention, the longitudinally opposite ends 17, 18 of the liquid-absorbent pad 3 may be bonded to the third regions W_3 below the first regions W_1 rather than to the first regions W_1 . The region 19 of the crotch section 8 at which the pad 3 is bonded to the inner side of the short pants 2 may have its upper end 19A extending upward beyond the crotch section 8 into a lower zone of the third region W_3 in the front waist section 6. The lower end 19B of the region 19 may extend beyond the lower ends 10B of the leg-openings 10 to a point adjacent the longitudinal middle of the crotch section 8. The topsheet 21 and the backsheet 22 of the short pants 2 may be replaced by sheets of liquid-impermeable plastic film. It is also possible without departing from the spirit and the scope of the invention to replace the first and second elastically stretchable members 13, 14 circumferentially extending around the wearer's waist by a plurality of stretchable members, respectively. The peripheral edge of each leg-opening 10 may be provided not only along a half of the rear side but also along a half of the front

side with the elastically stretchable member. When the crotch section 8 has a relatively high tensile stress, the elastically stretchable member 15 extending around the leg-openings may be eliminated. Concerning the pad 3, the transverse extensions of the backsheet 39 may be dimensioned to be relatively narrow and the elastically stretchable members 45 may be eliminated. Furthermore, for the bonding of the components of the short pants 2 as well as of the pad 3, any suitable means, such as hot melt adhesive or heating, may be used.

With the disposable absorbent undergarment according to the invention, the undergarment can be worn with the liquid-absorbent pad being tightly fitted against the wearer's crotch without demand for increased tensile stress in the elastically stretchable regions in the proximity of the waist-opening. This is due to the provision, immediately above the crotch section, of the elastically stretchable regions circumferentially extending around the wearer's waist so that these elastically stretchable regions may prevent the contracting force generated in the crotch section in the longitudinal direction from causing the pants to slip down. Such undergarment is comfortable to wear, since the contracting force generated circumferentially around the wearer's waist does not exert an excessive pressure on the central zone of the wearer's belly.

The elastically stretchable regions lying immediately above the crotch section press the longitudinally opposite ends of the pad against the wearer's body and cooperate with said contracting force to improve the fitting of the undergarment to the wearer's body.

Furthermore, the undergarment can be smoothly worn on the wearer's body without any apprehension that the liquid-absorbent pad might lift off from the crotch section or shift aside, since the pad is bonded to the inner side of the short pants in the proximity of the waist-opening and at the crotch section. Once the short pants have been worn, the proper position of the pad relative to the wearer's body is scarcely affected by a deformation of the short pants and practicably no interspace is generated between the pad and the wearer's body which might cause leakage of excretion. In addition, the pad is free relative to the short pants except at its longitudinally opposite ends and intermediate bonding region, so the presence of the pad does not adversely affect the circumferential stretchability of the short pants. In this manner, the short pants fit around the wearer's waist with a uniform tension and are comfortable to wear.

Claims

1. A disposable absorbent undergarment of pants type comprising short pants and a liquid-absorbent pad, said short pants being defined by a front waist section, a rear waist section and a crotch section interposed between said two waist sections and

having a pair of leg-openings and a circumferentially stretchable waist-opening, and said liquid-absorbent pad being attached inside of said short pants so as to extend longitudinally from said crotch section into said front and rear waist sections, wherein:

said crotch section extending below upper ends of said leg-openings is provided with first elastic means which is stretchable at least longitudinally of said crotch section;

a circumferential region defined by portions of said front and rear waist sections immediately above said crotch section is provided with second elastic means which is circumferentially stretchable; and

said liquid-absorbent pad comprises a liquid-permeable topsheet, a backsheet and a liquid-absorbent panel disposed between these two sheets with portions of said sheets extending outward beyond longitudinally opposite ends of said panel and being joined to said front and rear waist sections, respectively.

2. The undergarment as claimed in Claim 1, wherein said first elastic means in a stretched condition is continuous between said pair of leg-openings, a portion of said first elastic means extending substantially along halves of rear side peripheries of said respective leg-openings and another portion of said first elastic means extending across said crotch section in the proximity of lower ends of said leg-openings.
3. The undergarment as claimed in Claim 1 or 2, wherein said backsheet is liquid-impermeable.
4. The undergarment as claimed in Claim 1, 2 or 3, wherein said first elastic means provided in said crotch section and being stretchable at least longitudinally of said undergarment comprises a liquid-impermeable film.
5. The undergarment as claimed in any preceding Claim, wherein said pad is bonded, along a narrow region having a width of 1 to 3mm longitudinally extending on a transverse middle of said pad, to said crotch section, so that said pad can remain free relative to said short pants except said longitudinally opposite ends of said middle narrow region thereof.
6. The undergarment as claimed in Claim 5, wherein said bonding region provided on said crotch section is placed aside toward said front waist section.
7. The undergarment as claimed in any preceding Claim, wherein said short pants have a stretchability in the circumferential direction around the wear-

er's waist all over an area thereof vertically defined between a peripheral edge of said waist-opening and upper ends of the respective leg-openings.

5

10

15

20

25

30

35

40

45

50

55

6

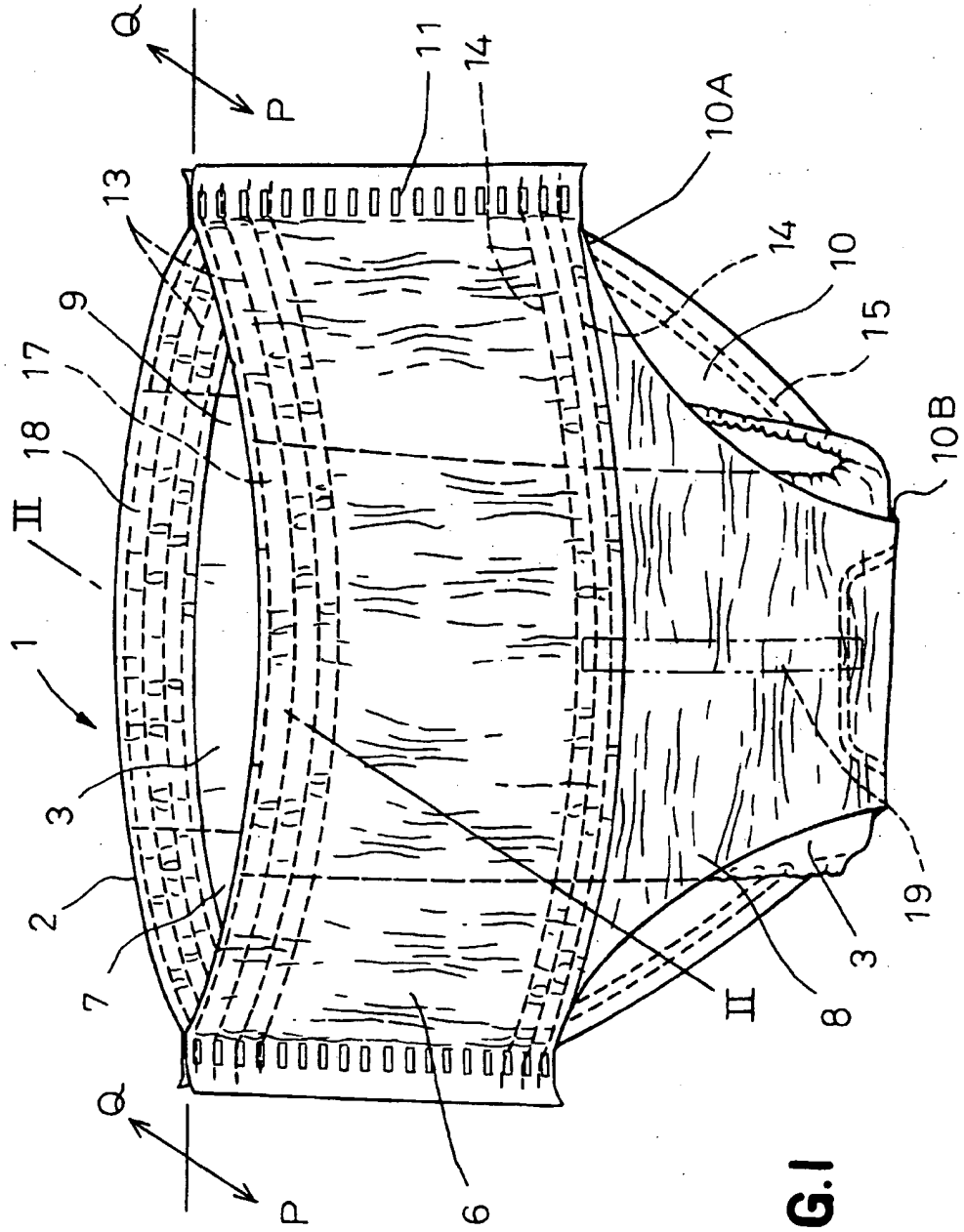

FIG.1

FIG.2

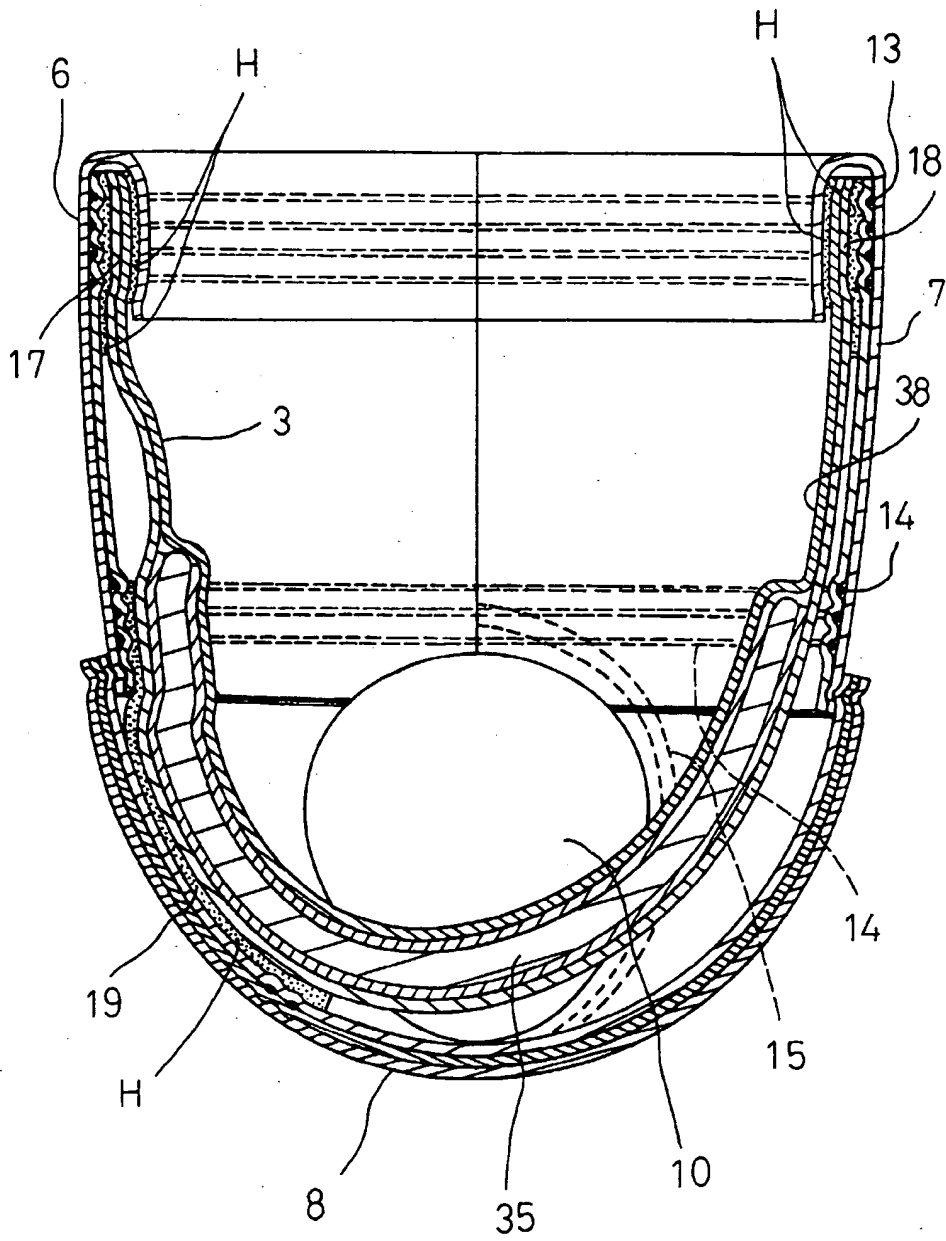
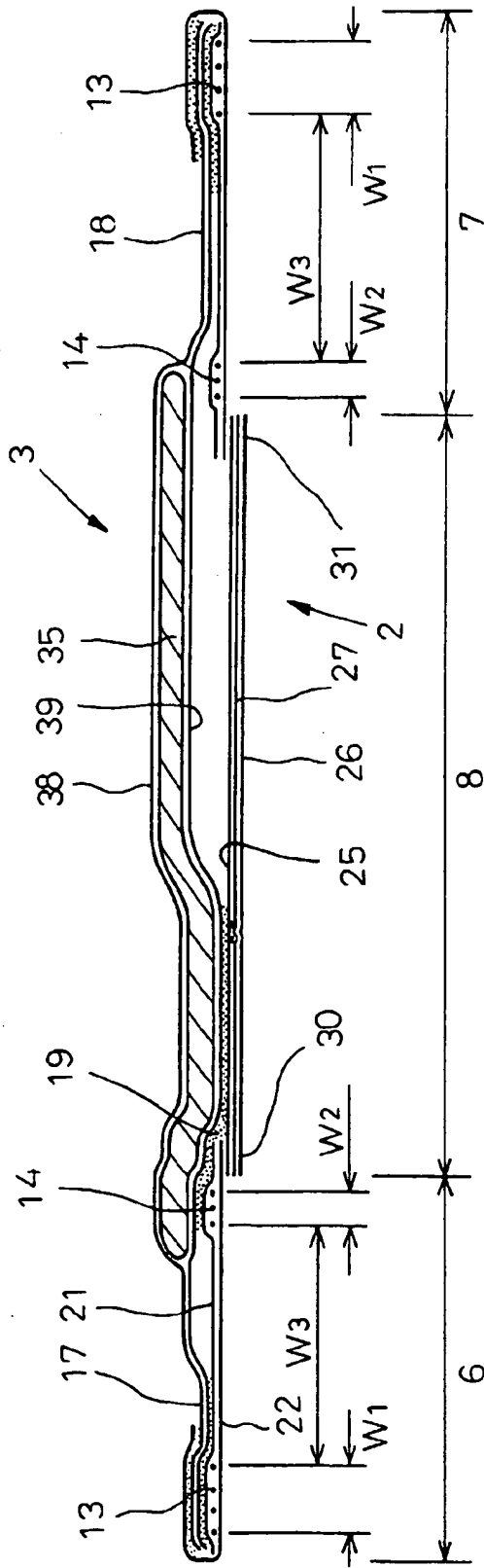

FIG.4



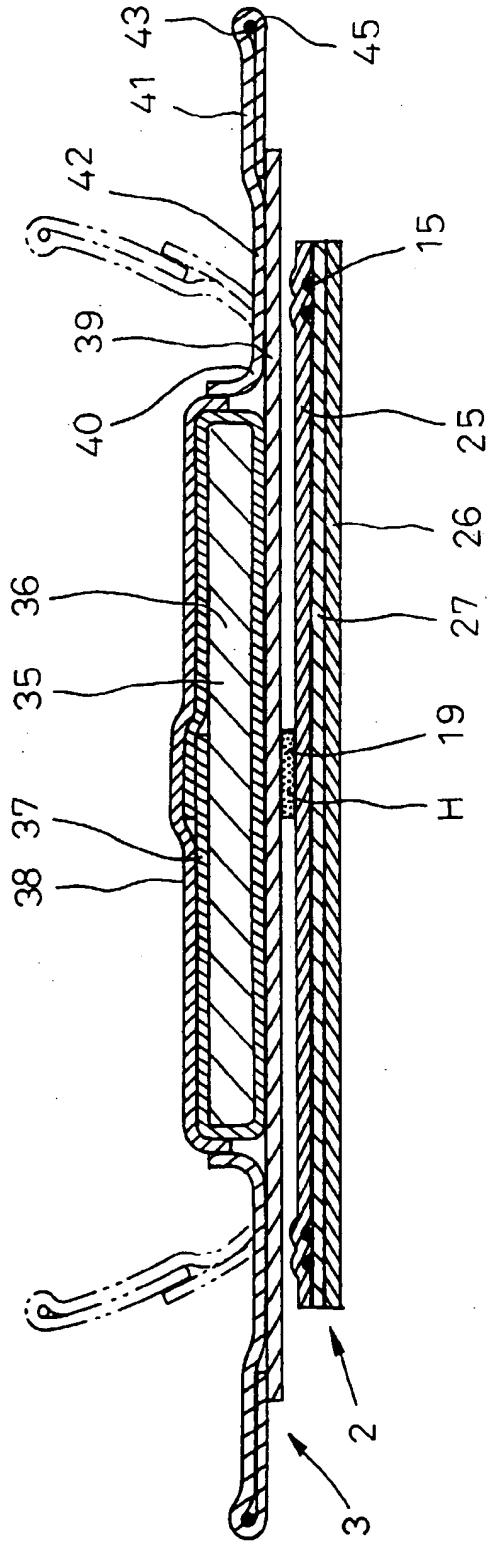

FIG.5

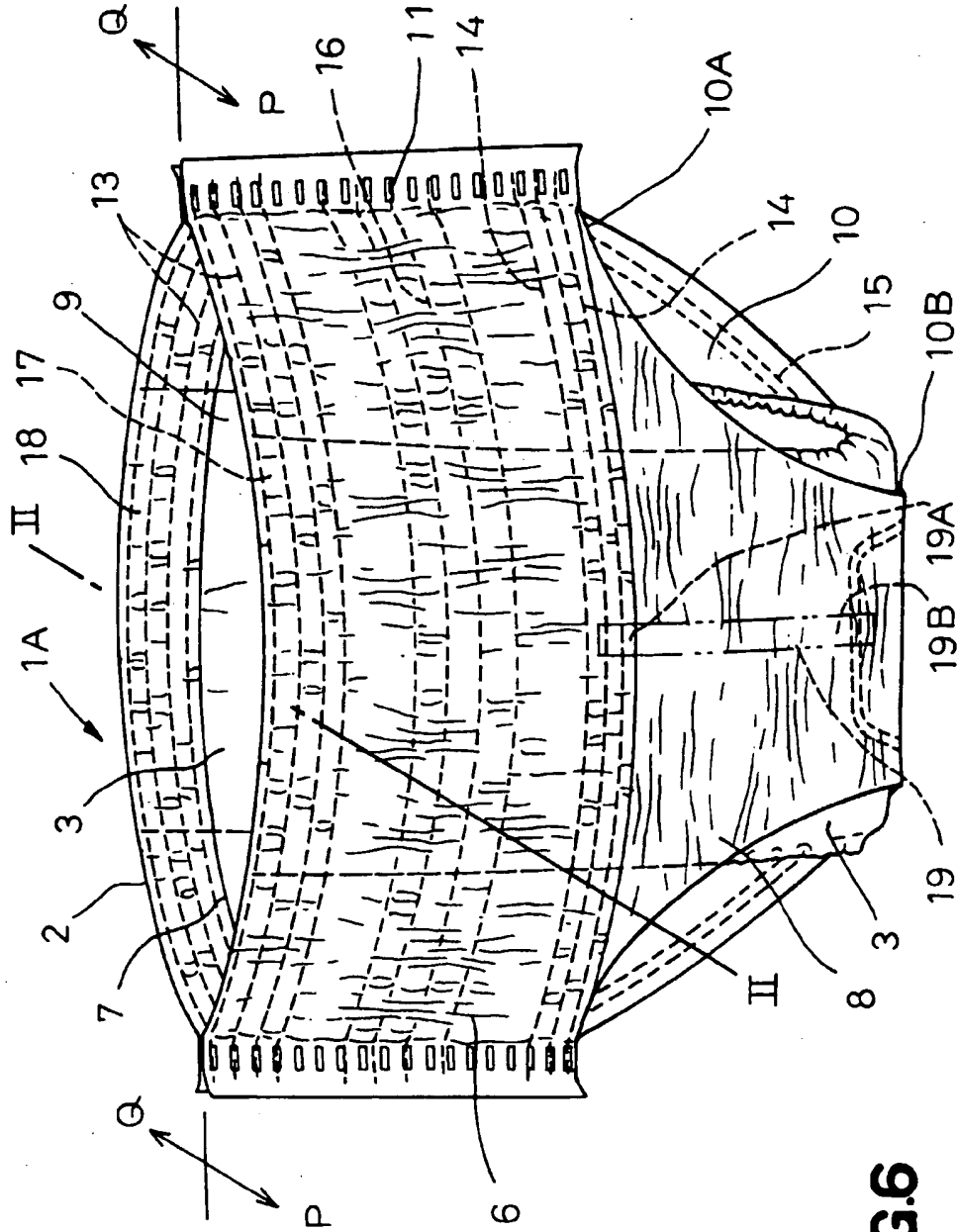

FIG.6

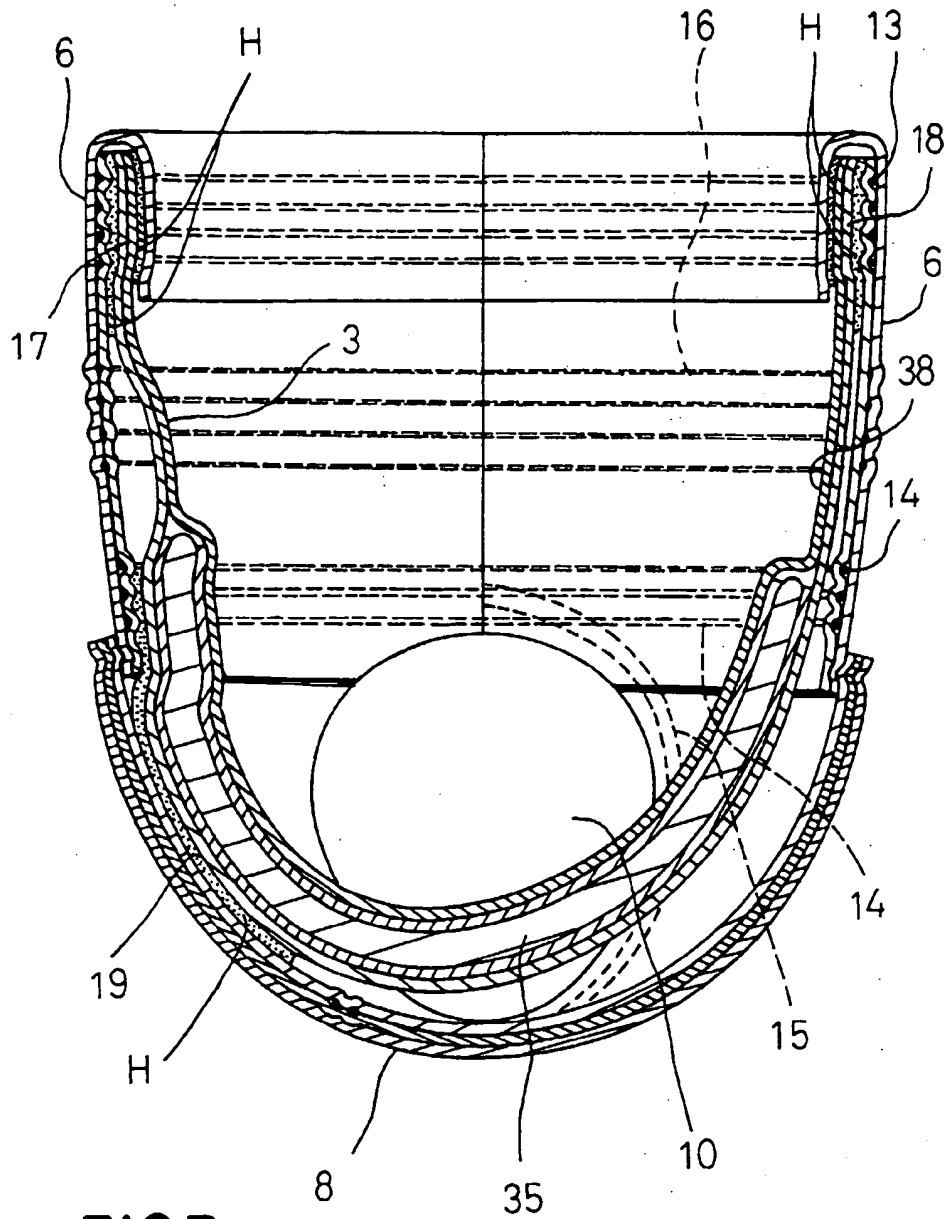

FIG.7

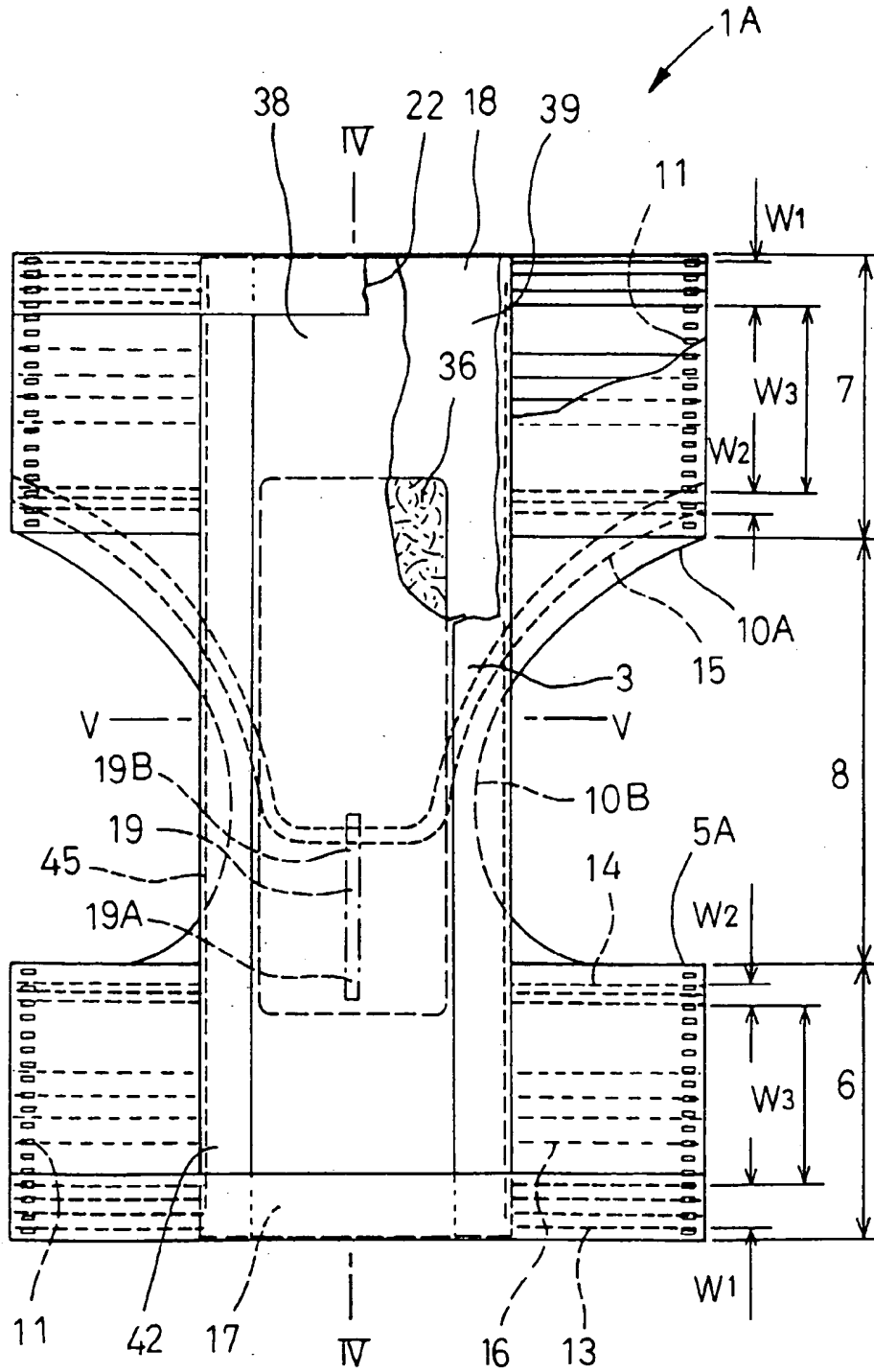

FIG.8

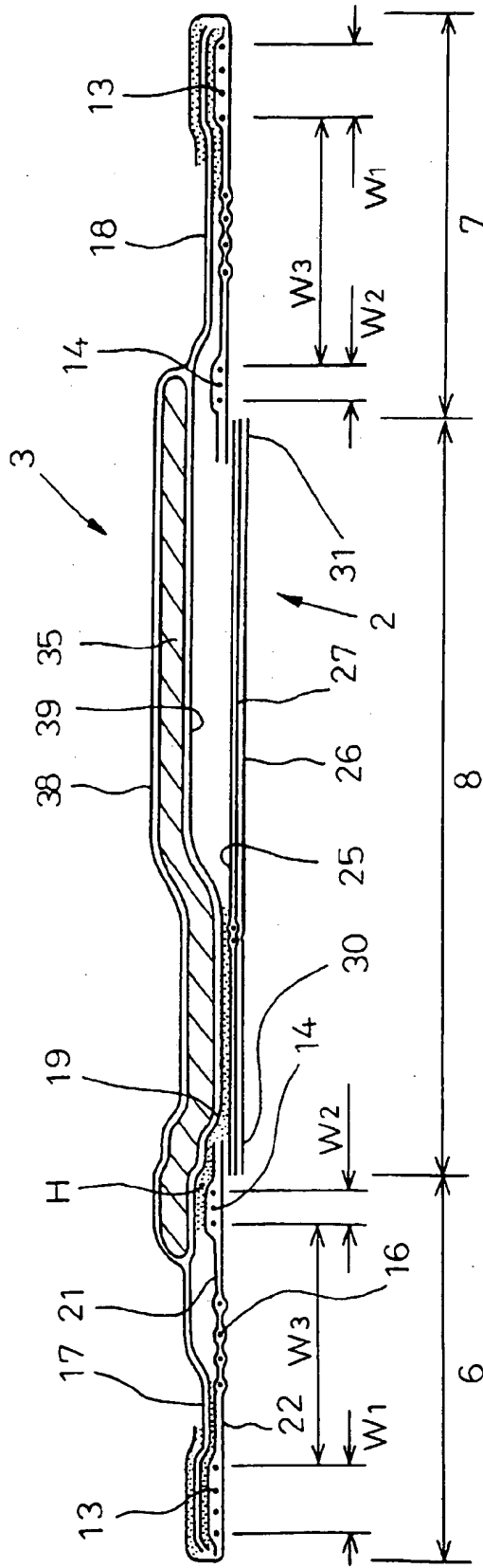

FIG.9

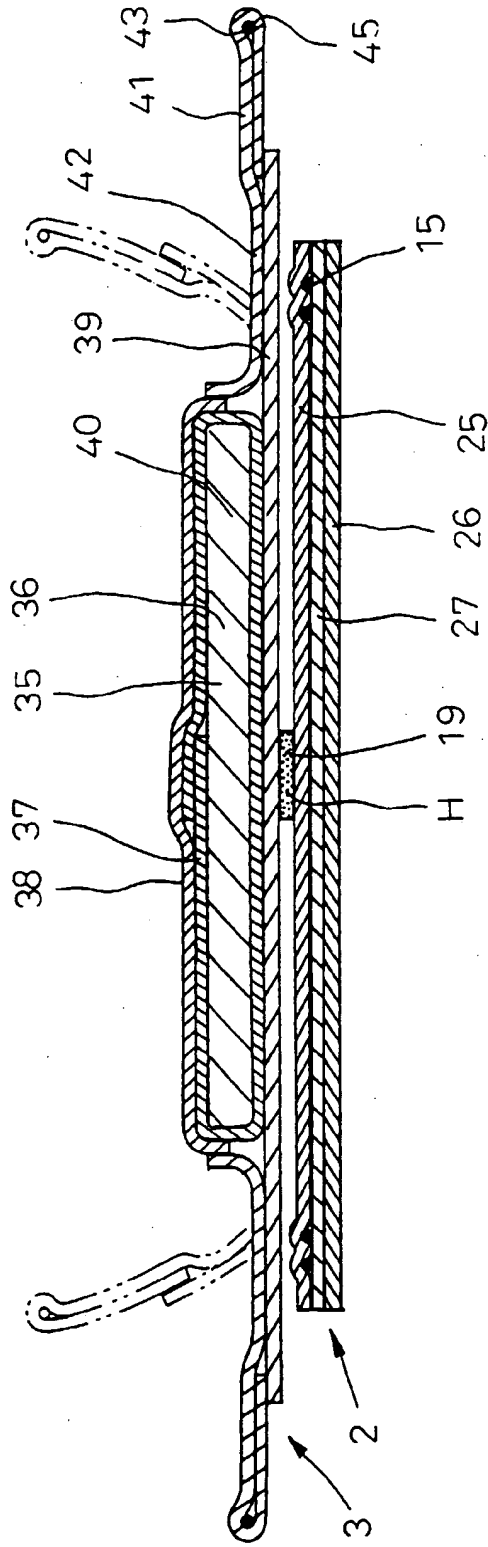

FIG.10

**This Page is Inserted by IFW Indexing and Scanning
Operations and is not part of the Official Record**

BEST AVAILABLE IMAGES

Defective images within this document are accurate representations of the original documents submitted by the applicant.

Defects in the images include but are not limited to the items checked:

- BLACK BORDERS
- IMAGE CUT OFF AT TOP, BOTTOM OR SIDES
- ~~FADED TEXT OR DRAWING~~
- BLURRED OR ILLEGIBLE TEXT OR DRAWING
- SKEWED/SLANTED IMAGES
- COLOR OR BLACK AND WHITE PHOTOGRAPHS
- GRAY SCALE DOCUMENTS
- LINES OR MARKS ON ORIGINAL DOCUMENT
- REFERENCE(S) OR EXHIBIT(S) SUBMITTED ARE POOR QUALITY
- OTHER: _____

IMAGES ARE BEST AVAILABLE COPY.

As rescanning these documents will not correct the image problems checked, please do not report these problems to the IFW Image Problem Mailbox.